



SERVICE BULLETIN

Classification: BT02-031	Reference: NTB02-122	Date: December 11, 2002
-----------------------------	-------------------------	----------------------------

2003 350Z; INTERIOR SQUEAK AND RATTLE REPAIR

APPLIED VEHICLE: 2003 350Z (Z33)

IF YOU CONFIRM:

A 2003 350Z exhibits squeak and rattle noise(s),

ACTIONS:

Use the following Service Procedure sections to resolve the incident(s):

Squeak and Rattle Diagnostic Customer Worksheet - MUST be filled out with customer PRIOR to beginning repair(s).

- Front Area, Upper (dashboard, lower windshield)
- Upper Area (headliner, upper windshield, sunroof)

IMPORTANT: The purpose of **ACTIONS** (above) is to give you a quick idea of the work you will be performing. You **MUST** closely follow the **entire Service Procedure** (starting on page 2, below) as it contains information that is essential to successfully completing this repair.

PARTS INFORMATION

DESCRIPTION	PART NUMBER	QUANTITY
Sunvisor Vanity Mirror Bulb	26447-CD660	1
Sunvisor Vanity Mirror Lens	26442-CD660	1

CLAIMS INFORMATION

Please reference Nissan Claims Bulletin WB/98-021a and Section "UX - Squeak & Rattle Repairs" of the current Nissan "Warranty Flat Rate Manual" for complete details regarding policy and claims coding applicable to the repair of squeaks and rattles.

Expense Details:

Only claim (pro-rate) the amount of squeak and rattle material that is actually used for the repair. Claim this amount using expense code 022. Do not claim the repair material(s) part number(s) on the claim. For complete details, reference Nissan TSB NTB98-110 - Nissan Vehicle Squeak and Rattle Materials."

If the mirror switch is replaced, submit a separate Primary Failed Part (PP) line claim using the following claims coding:

DESCRIPTION	PFP	OP CODE	SYM	DIA	FRT
RPL Vanity Mirror Lamp/Switch Assy.	26447-CD660	RF18AA	ZL	32	*

* Reference the current Nissan Warranty Flat Rate Manual and use the indicated FRT.

SERVICE PROCEDURE

Squeak and Rattle Diagnostic Customer Worksheet

This worksheet is used to help duplicate, identify and isolate squeaks and rattles. Click on the bookmark at left to pull this worksheet up or refer to the Squeak and Rattle Diagnostic Worksheet section in the printed copy of this bulletin.

The worksheet MUST be filled out with the customer PRIOR to beginning the repair(s). Customer input is important.

Front Area, Upper (dashboard, lower windshield)

Click on the bookmark at left to access this section or refer to the Front Area, Upper section in the printed copy of this bulletin. This section includes:

- dash pad and instrument cluster,
- dash internal structure and components,
- windshield to dash interface area,
- glove box,
- audio and HVAC controls and vents.

Upper Area (headliner, upper windshield, sunroof)

Click on the bookmark at left to access this section or refer to the Upper Area section in the printed copy of this bulletin. This section includes:

- roof,
- A, B, C, D pillars and trim,
- sun visors,
- electrical control panels in headliner or visors,
- pillar mounted seat belt retractors.

SQUEAK & RATTLE DIAGNOSTIC WORKSHEET

Dear Nissan Customer:

We are concerned about your satisfaction with your Nissan vehicle. Repairing a squeak or rattle sometimes can be very difficult. To help us fix your Nissan right the first time, please take a moment to note the area of the vehicle where the squeak or rattle occurs and under what conditions. You may be asked to take a test drive with a service advisor or technician to ensure we hear and understand the noise you are hearing.

I. WHERE DOES THE NOISE COME FROM? (circle the area of the vehicle)

The illustrations are for reference only, and may not reflect the actual configuration of your vehicle.

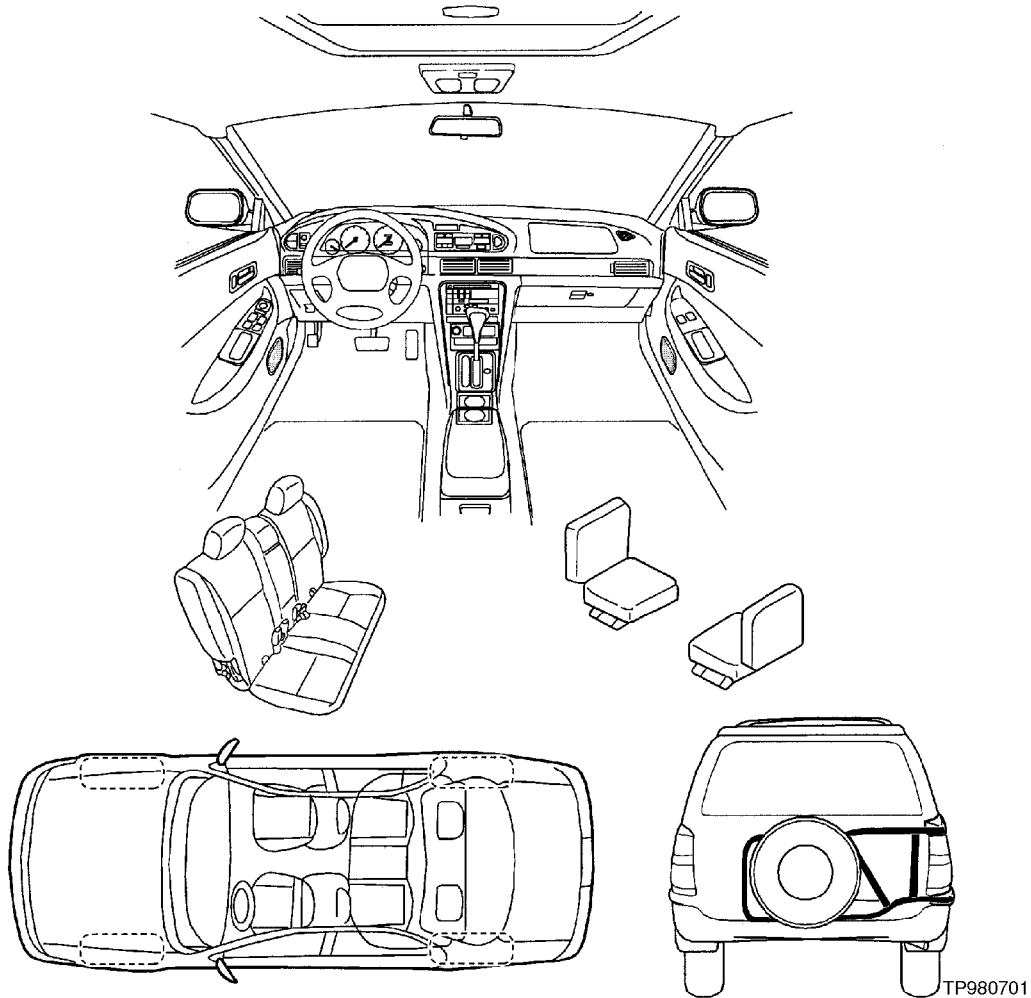

Continue to page 2 of the worksheet and briefly describe the location of the noise or rattle. In addition, please indicate the conditions which are present when the noise occurs.

SQUEAK & RATTLE DIAGNOSTIC WORKSHEET- page 2

Briefly describe the location where the noise occurs:

II. WHEN DOES IT OCCUR? (check the boxes that apply)

- | | |
|--|---|
| <input type="checkbox"/> anytime | <input type="checkbox"/> after sitting out in the sun |
| <input type="checkbox"/> 1 st time in the morning | <input type="checkbox"/> when it is raining or wet |
| <input type="checkbox"/> only when it is cold outside | <input type="checkbox"/> dry or dusty conditions |
| <input type="checkbox"/> only when it is hot outside | <input type="checkbox"/> other: _____ |

III. WHEN DRIVING:

- through driveways
- over rough roads
- over speed bumps
- only at about ____ mph
- on acceleration
- coming to a stop
- on turns : left, right or either (circle)
- with passengers or cargo
- other: _____
- after driving ____ miles or ____ minutes

IV. WHAT TYPE OF NOISE?

- squeak (like tennis shoes on a clean floor)
- creak (like walking on an old wooden floor)
- rattle (like shaking a baby rattle)
- knock (like a knock on a door)
- tick (like a clock second hand)
- thump (heavy, muffled knock noise)
- buzz (like a bumble bee)

TO BE COMPLETED BY DEALERSHIP PERSONNEL

Test Drive Notes:

	<u>YES</u>	<u>NO</u>	<u>Initials of person performing</u>
Vehicle test driven with customer	<input type="checkbox"/>	<input type="checkbox"/>	_____
- Noise verified on test drive	<input type="checkbox"/>	<input type="checkbox"/>	_____
- Noise source located and repaired	<input type="checkbox"/>	<input type="checkbox"/>	_____
- Follow up test drive performed to confirm repair	<input type="checkbox"/>	<input type="checkbox"/>	_____

VIN: _____ Customer Name: _____

W.O. #: _____ Date: _____

This form must be attached to Work Order

TP980702

FRONT AREA, UPPER for 2003 350Z

The front area, upper includes:

- dash pad and instrument cluster,
- dash internal structure and components,
- windshield to dash interface area,
- glove box,
- audio and HVAC controls and vents.

NOTE: Read through all of the incidents listed in this section that apply to the incident area in the vehicle. Some repairs may need to be done in combination with others.

WARNING: If a part of the SRS (air bag) needs to be serviced, always turn the ignition switch off, disconnect both battery cables and wait at least three (3) minutes before performing the service.

1) Light “wine glass ping”/high-frequency metallic noise from the center upper windshield of vehicle.

Verify:

This noise may occur when driving on pavement or rough roads at speeds over 20 MPH.

Isolate:

This incident may be duplicated by performing the following static test, or during a test drive:

1. With the sunvisor in the PARTIALLY OPEN position, lightly tap on the sunvisor to duplicate the noise (see Figure 1A).
2. With the sunvisor and vanity mirror in the COMPLETELY OPEN position (with the vanity mirror light turned “on”), lightly tap on the sunvisor again (see Figure 1B). If the noise is no longer present, proceed to the Repair section, below.

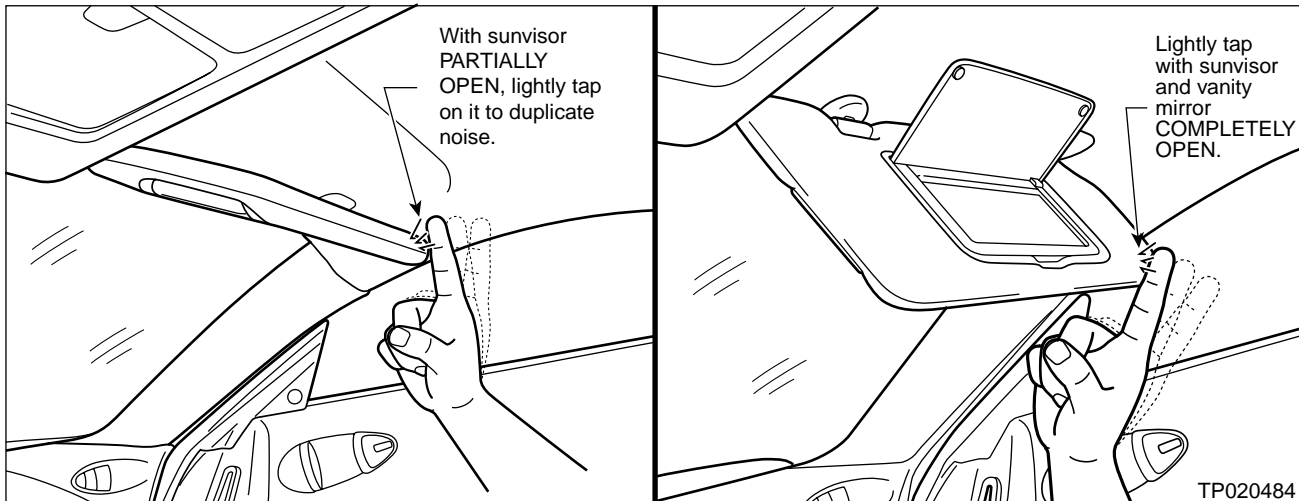

Figure 1A

Figure 1B

Repair:

1. Replace the original sunvisor vanity mirror light bulb and lens with a replacement bulb and lens (see Figure 2). See the PARTS INFORMATION section for detail:
 - A. Insert a thin screwdriver in the lens end and remove the lens.
 - B. Remove the vanity mirror light bulb (vanity mirror lamp: 12V - 1.32W).
 - C. Install the replacement bulb.
 - D. Install the replacement lens.

NOTE: The upper switch contact has been increased in thickness on the replacement bulb. See Figure 3.

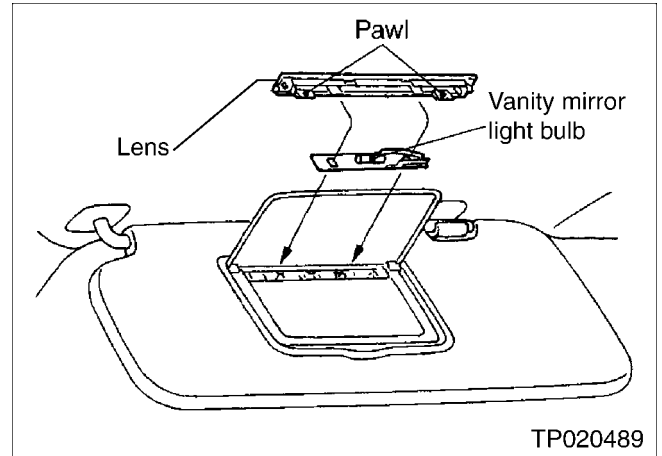

Figure 2

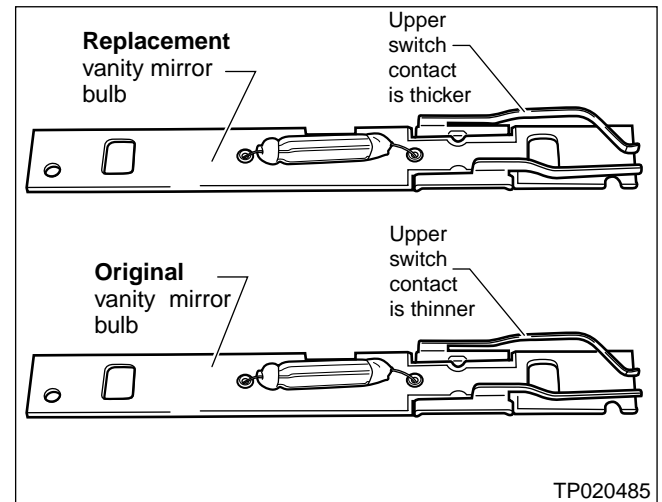

Figure 3

Recheck:

Test the vehicle as described above to confirm the repair is complete.

2) Light metallic rattle from lower dash board area, between Vehicle Dynamic Control (VDC) unit switch and steering column.

This noise may occur ONLY on Manual Transmission vehicles, in Touring, Performance, or Track models.

Verify:

This noise may occur when driving on pavement or rough roads at speeds over 20 MPH.

Isolate:

This noise may be caused by loose VDC unit attaching bolts.

Repair:

1. Remove the driver-side lower instrument panel. Refer to IP-11, INSTRUMENT PANEL ASSEMBLY.
2. Tap the VDC unit to verify if noise occurs (see Figure 4).
3. Examine the VDC unit bolts for looseness (see Figure 4).
4. Tighten the bolts to 4.3 - 5.8 N-m (0.44 – 0.59 kg-m, 38 - 51 in-lb). See Figure 4

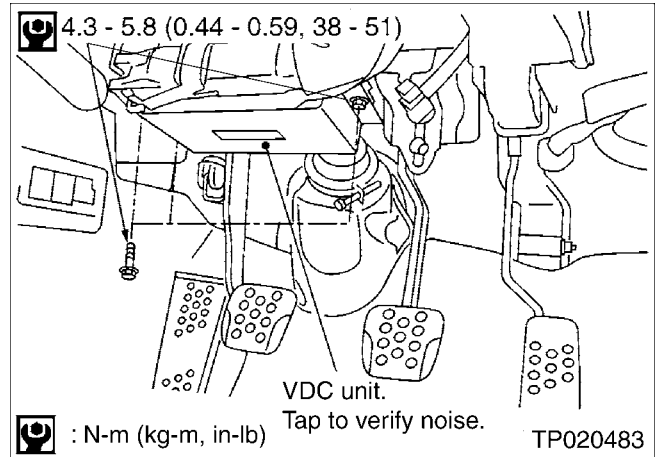

Figure 4

Recheck:

Test the vehicle as described above to confirm the repair is complete.

UPPER AREA for 2003 350Z

The upper area includes:

- roof,
- A, B, C, D pillars and trim,
- sun visors,
- electrical control panels in headliner or visors,
- pillar mounted seat belt retractors.

NOTE: Read through all of the incidents listed in this section that apply to the incident area in the vehicle. Some repairs may need to be done in combination with others.

WARNING: If a part of the SRS (air bag) needs to be serviced, always turn the ignition switch off, disconnect both battery cables and wait at least three (3) minutes before performing the service.

1) Light tapping noise from upper right-hand or left-hand side of vehicle.

Verify:

This noise may occur when driving on pavement or rough roads at speeds over 20 MPH.

Isolate:

While on a test drive, this noise may be changed (stops or gets weaker) by applying direct pressure to the leading edge of the headliner, where it meets the windshield and A-pillar (see Figure 1).

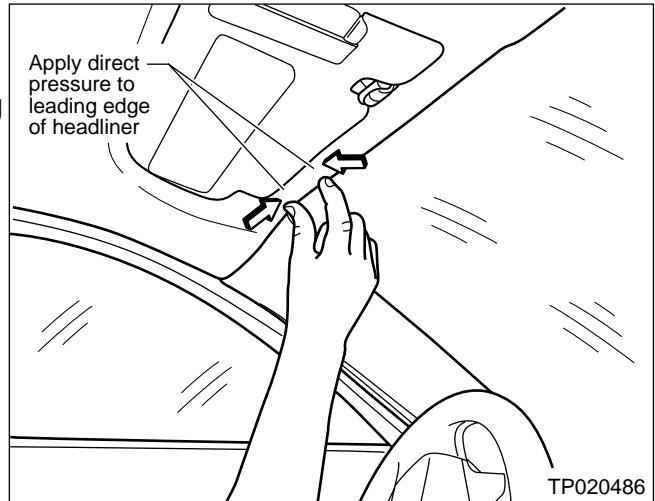

Figure 1

This noise may be caused by the front edge of the headliner (near top of A-pillar) tapping against the windshield. The headliner may not have enough clearance at the windshield.

Inspect 1" - 3" (25 - 76 mm) long section of the headliner from the A-pillar toward the center of the vehicle. Check to see if there is enough clearance between the headliner and the windshield (see Figure 2).

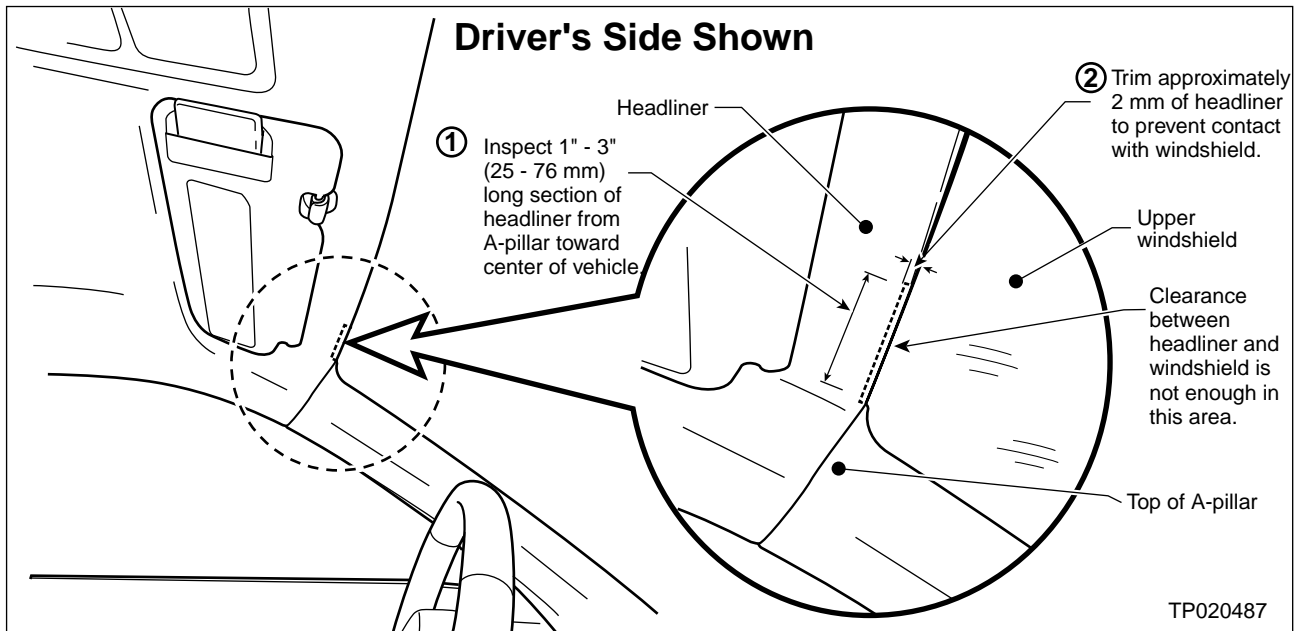

Figure 2

Repair:

If there is not enough clearance between headliner and windshield, trim approximately 2 mm of headliner, where needed (see Figure 2).

Recheck:

Test drive the vehicle to confirm noise is no longer present.

2) Hollow rattle from passenger side of vehicle.

Verify:

This noise may occur when driving on pavement or rough roads at speeds over 20 MPH.

Isolate:

This noise may be caused by contact between the passenger-side seat belt latch plate and the B-pillar.

Repair:

1. Examine the passenger-side seat belt to see how it is secured.
2. Insert both the latch plate **and** the seat belt into the seat belt clip. This is located on the passenger-side B-pillar (see Figure 3C).

NOTE: If the seat belt and latch plate **are not completely and properly inserted into the seat belt clip**, the rattle will not be eliminated. See Figures 3A and 3B for examples of incorrectly inserted seat belt/latch plate.

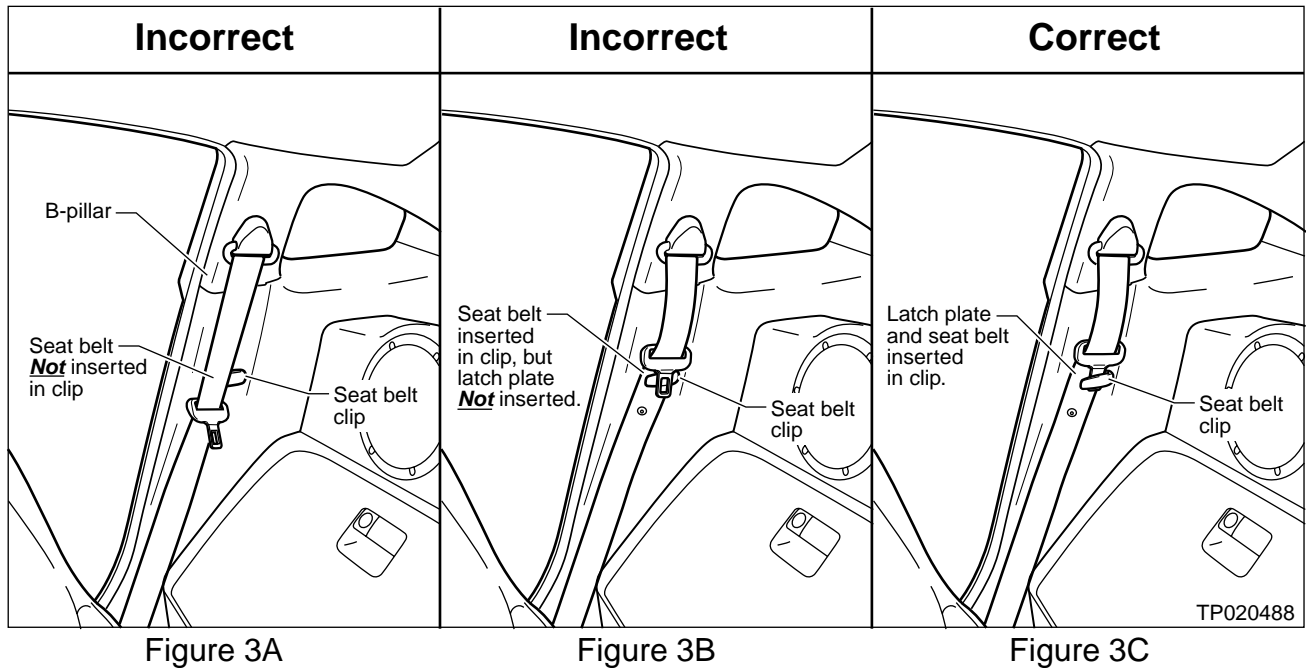

Recheck:

Test drive the vehicle to confirm noise is no longer present.

IMPORTANT NOTE: After you have properly inserted both the seat belt and latch plate in the seat belt clip and completed the test drive, show the customer to “educate” them on proper use.