

SECTION **FL**  
FUEL SYSTEM

A  
FL  
C  
D  
E  
F  
G  
H  
I  
J  
K  
L  
M

CONTENTS

<b>PRECAUTIONS</b> .....	2	INSPECTION AFTER INSTALLATION .....	8
Precautions for Battery Service .....	2	Disassembly and Assembly .....	8
<b>FUEL SYSTEM</b> .....	3	DISASSEMBLY .....	8
Checking Fuel Lines .....	3	ASSEMBLY .....	9
General Precautions .....	3	<b>FUEL TANK</b> .....	10
<b>FUEL LEVEL SENSOR UNIT, FUEL FILTER AND</b>		Removal and Installation .....	10
<b>FUEL PUMP ASSEMBLY</b> .....	4	REMOVAL .....	10
Removal and Installation .....	4	INSTALLATION .....	11
REMOVAL .....	4	INSPECTION AFTER INSTALLATION .....	11
INSTALLATION .....	7	<b>SERVICE DATA AND SPECIFICATIONS (SDS) .....</b>	12
		Standard and Limit .....	12
		Tightening Torque .....	12

# PRECAUTIONS

---

## PRECAUTIONS

PFP:00001

### Precautions for Battery Service

ABS00A3D

Before disconnecting the battery, lower both the driver and passenger windows. This will prevent any interference between the window edge and the vehicle when the door is opened/closed. During normal operation, the window slightly raises and lowers automatically to prevent any window to vehicle interference. The automatic window function will not work with the battery disconnected.

## FUEL SYSTEM

PFP:17503

### Checking Fuel Lines

ABS009QM

Inspect fuel lines, filler cap and tank for improper attachment, leaks, cracks, damage, loose connections, chafing or deterioration. If necessary, repair or replace damaged parts.

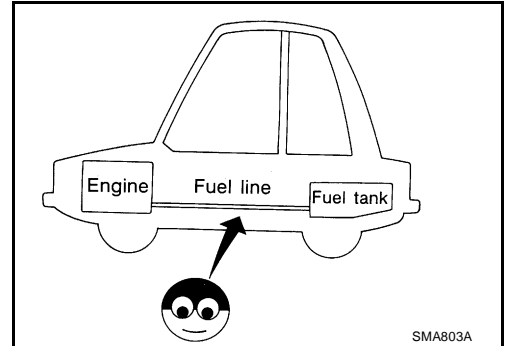

ABS009QN

### General Precautions

#### WARNING:

When replacing fuel line parts, be sure to observe the following.

- Put a "CAUTION: INFLAMMABLE" sign in the workshop.
- Be sure to work in a well ventilated area and furnish workshop with a CO<sub>2</sub> fire extinguisher.
- Do not smoke while servicing fuel system. Keep open flames and sparks away from the work area.
- Put drained fuel in an explosion-proof container and put the lid on securely. Keep the container in safe area.

#### CAUTION:

- Before removing fuel line parts, perform the following procedures:

- Release fuel pressure from the fuel lines. Refer to [EC-45, "FUEL PRESSURE RELEASE"](#) .
- Disconnect negative battery terminal.

- Always replace O-rings and clamps with new ones.
- Do not kink or twist tubes when they are being installed.
- Do not tighten hose clamps excessively to avoid damaging hoses.

- After connecting fuel tube quick connectors, make sure quick connectors are secure. Ensure that connector and resin tube do not contact any adjacent parts.

- After installing tubes, make sure there is no fuel leakage at connections in the following steps.

- Apply fuel pressure to fuel lines with turning ignition switch "ON" (with engine stopped). Then check for fuel leaks at connections.
- Start engine and rev it up and check for fuel leaks at connections.

- Use only a genuine NISSAN fuel filler cap as a replacement. If an incorrect fuel filler cap is used, the "MIL" may come on.

- For servicing "Evaporative Emission System" parts, refer to [EC-674, "EVAPORATIVE EMISSION SYSTEM"](#) .

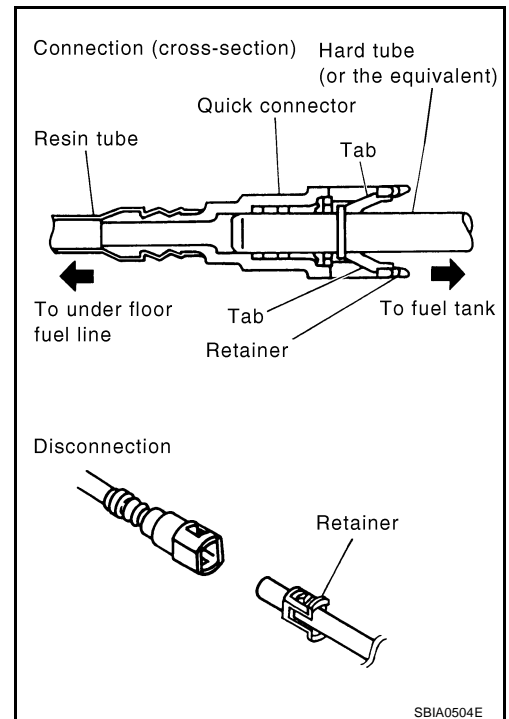

SBIA0504E

# FUEL LEVEL SENSOR UNIT, FUEL FILTER AND FUEL PUMP ASSEMBLY

## FUEL LEVEL SENSOR UNIT, FUEL FILTER AND FUEL PUMP ASSEMBLY PFP:17042

### Removal and Installation

ABS009Q0

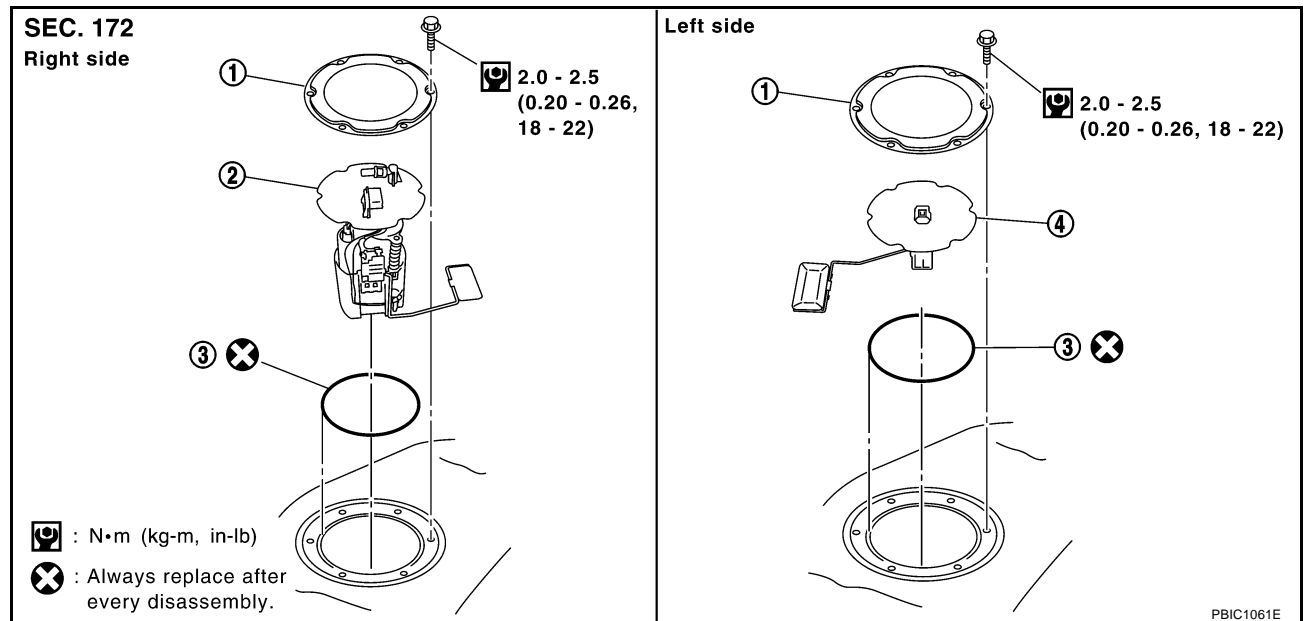

1. Retainer
2. Main fuel level sensor unit, fuel filter - and fuel pump assembly
3. O - ring
4. Sub fuel level sensor unit

### REMOVAL

#### WARNING:

Be sure to read "General Precautions" when working on the fuel system. Refer to [FL-3, "General Precautions"](#).

1. Check fuel level on fuel gauge. If fuel gauge indicates more than the level as shown in the figure (full or almost full), drain fuel from fuel tank until gauge indicates level as shown in the figure or below.

#### NOTE:

Because fuel will be spilled when removing main and sub fuel level sensor units for the top of the fuel is above the main and sub fuel level sensor units installation surface.

- As a guide, fuel level becomes the position as shown in the figure or below when approximately 20 ℓ (5-1/4 US gal, 4-3/8 Imp gal) of fuel are drained from fuel tank.
  - In a case that fuel pump does not operate, perform the following procedure.
    - a. Insert hose of less than 25 mm (0.98 in) in diameter into fuel filler tube through fuel filler opening to draw fuel from fuel filler tube.
    - b. Disconnect fuel filler hose from fuel filler tube. Refer to [FL-10, "FUEL TANK"](#).
    - c. Insert hose into fuel tank through fuel filler hose to draw fuel from fuel tank.
2. Release the fuel pressure from the fuel lines. Refer to [EC-45, "FUEL PRESSURE RELEASE"](#).
  3. Open fuel filler lid.
  4. Open filler cap and release the pressure inside fuel tank.
  5. Remove woofer or rear floor box mat and rear floor box. Refer to [AV-43, "Removal and Installation of Woofer and Woofer Amp. \(BOSE System\)"](#) or [EI-39, "LUGGAGE FLOOR TRIM"](#).

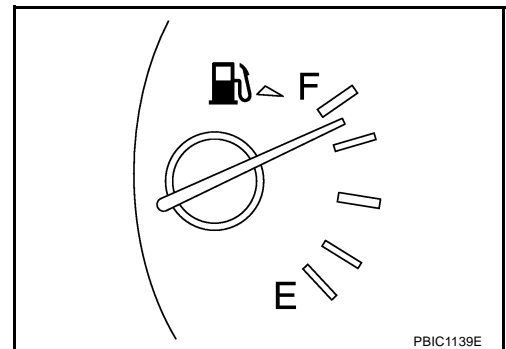

# FUEL LEVEL SENSOR UNIT, FUEL FILTER AND FUEL PUMP ASSEMBLY

6. Remove inspection hole cover for main and sub fuel level sensor units by turning clips clockwise by 90 degrees.

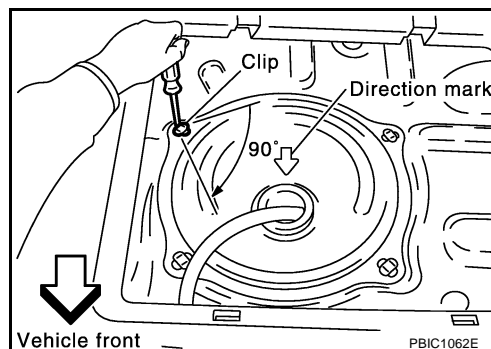

7. Disconnect harness connector and quick connector.

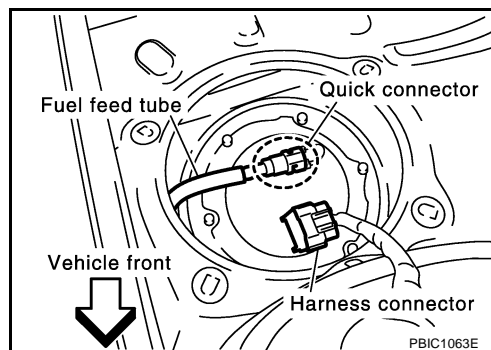

Disconnect quick connector as follows:

- Hold the sides of connector, push in tabs and pull out fuel feed tube.
- If quick connector sticks to tube of fuel level sensor unit, push and pull quick connector several times until it starts to move. Then disconnect quick connector by pulling.

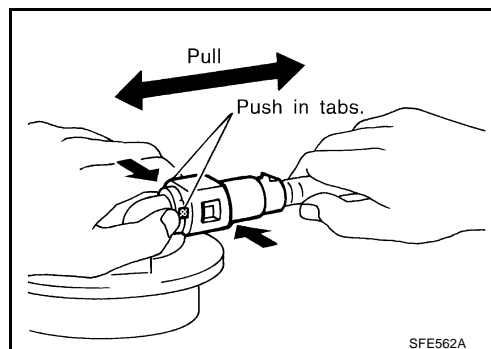

# FUEL LEVEL SENSOR UNIT, FUEL FILTER AND FUEL PUMP ASSEMBLY

**CAUTION:**

- Quick connector can be disconnected when the tabs are completely depressed. Do not twist it more than necessary.
- Do not use any tools to disconnect quick connector.
- Keep resin tube away from heat. Be especially careful when welding near the resin tube.
- Prevent acid liquid such as battery electrolyte, etc. from getting on resin tube.
- Do not bend or twist resin tube during installation and disconnection.
- Do not remove the remaining retainer on hard tube (or equivalent) except when resin tube or retainer is replaced.
- When resin tube or hard tube (or equivalent) is replaced, also replace retainer with new one.
- Replace same color retainer as before replacing.

Retainer color: White

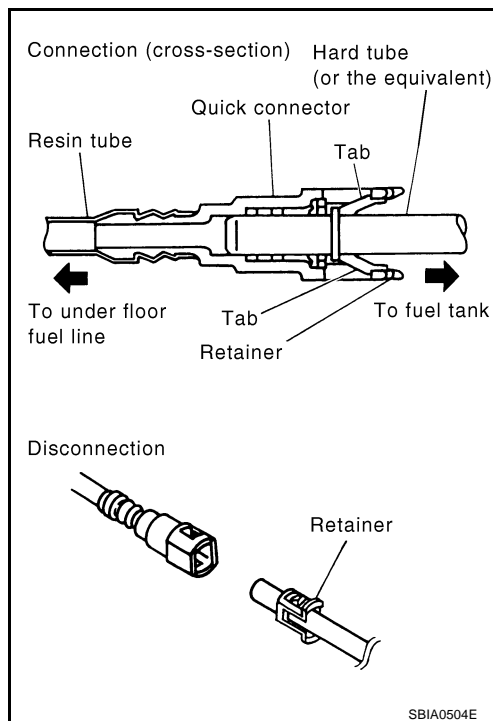

- To keep the connecting portion clean and to avoid damage and foreign materials, cover them completely with plastic bags or something similar.

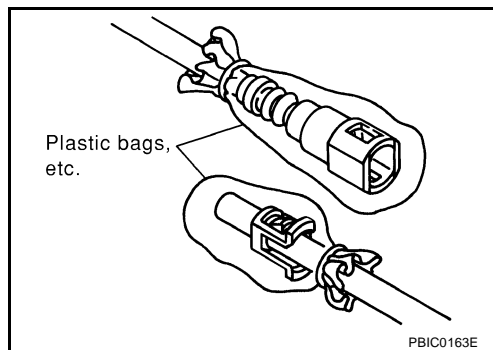

8. Remove main fuel level sensor unit, fuel filter and fuel pump assembly, and sub fuel level sensor unit as follows.

**CAUTION:**

- Do not bend float arm during removal.
- Avoid polluting the inside by residue fuel. Draw out with avoiding inclination by supporting with a cloth.
- Avoid impacts such as falling when handling components.

- a. Removal of main fuel level sensor unit, fuel filter and fuel pump assembly:
  - i. Remove retainer.
  - ii. Raise main fuel level sensor unit, fuel filter and fuel pump assembly, and using snap ring pliers, remove fuel hose connector.

**CAUTION:**

Be careful not to damage fuel hose connector by expanding them excessively.

- b. Removal of sub fuel level sensor unit:
  - i. Remove retainer.
  - ii. Raise and release sub fuel level sensor unit to remove.

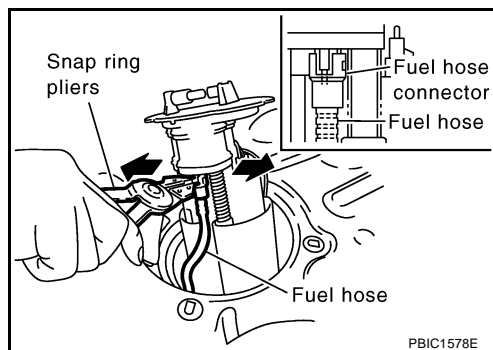

# FUEL LEVEL SENSOR UNIT, FUEL FILTER AND FUEL PUMP ASSEMBLY

## INSTALLATION

Note the following, and install in the reverse order of removal.

### Main and Sub Fuel Level Sensor Unit

- When installing fuel hose connector insert them fully until a click sound of full stopper engagement is heard.

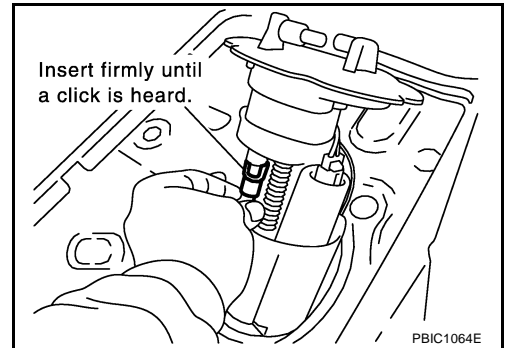

- Face main and sub fuel level sensor units as shown in the figure, and install them with the knock pin on back aligned with pin hole on fuel tank.

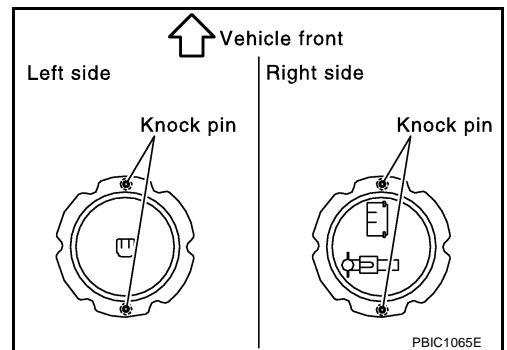

- Install retainer so that its notch becomes parallel with the notch on fuel tank.

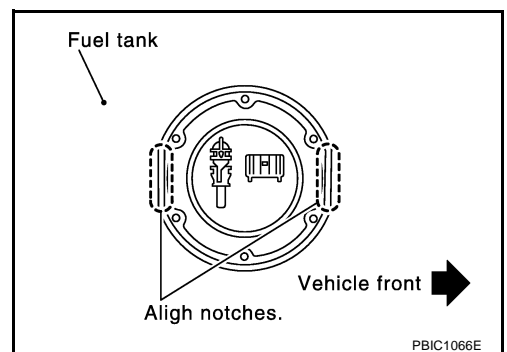

- Tighten retainer mounting bolts evenly.

### Quick Connector

Connect quick connector of fuel feed hose as follows:

1. Check the connection for damage or any foreign materials.
2. Align the connector with the tube, then insert the connector straight into the tube until a click sound is heard.
3. After connecting, make sure that the connection is secure by following method.
  - Visually confirm that the two tabs are connected to the connector.

# FUEL LEVEL SENSOR UNIT, FUEL FILTER AND FUEL PUMP ASSEMBLY

- Pull the tube and the connector to make sure they are securely connected.

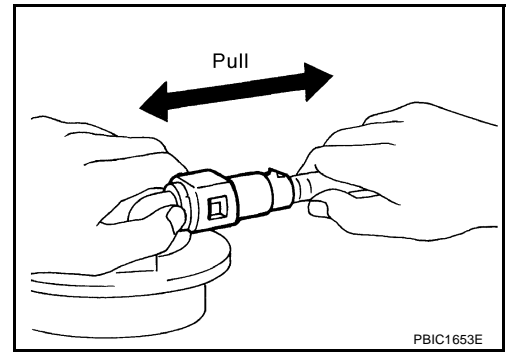

## Inspection Hole Cover

1. Install inspection hole cover with direction mark (arrow) facing front of vehicle.
2. Lock clips by turning counter-clockwise.

## INSPECTION AFTER INSTALLATION

Use the following procedure to check for fuel leaks.

1. Turn ignition switch "ON" (with engine stopped), then check connections for leaks by applying fuel pressure to fuel piping.
2. Start engine and rev it up and make sure there are no fuel leaks at the fuel system connections.

## Disassembly and Assembly

ABS009QP

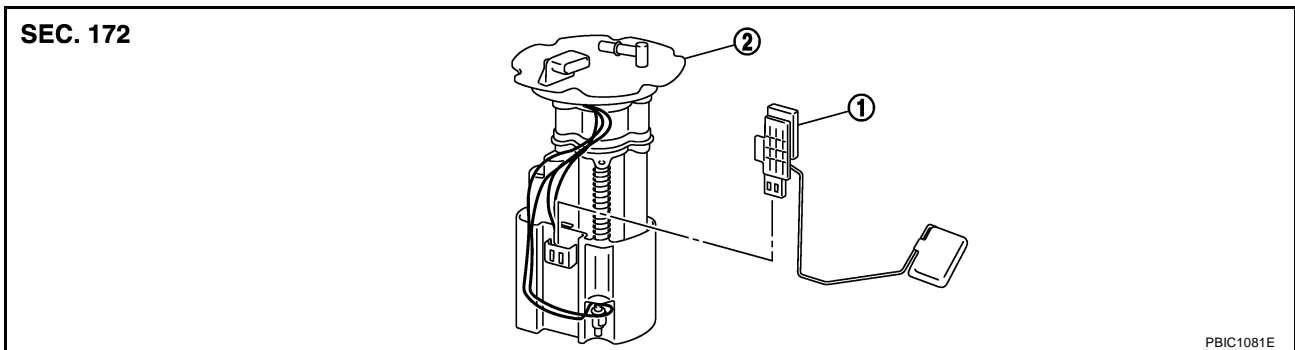

1. Fuel level sensor unit

2. Fuel filter and fuel pump assembly

### CAUTION:

Sub fuel level sensor unit cannot be disassembled and should be replaced as a unit.

## DISASSEMBLY

Remove fuel level sensor unit as follows.

1. Disconnect harness connector.
  - Hold connector by fingers and pull it out, because there is no stopper release tab.

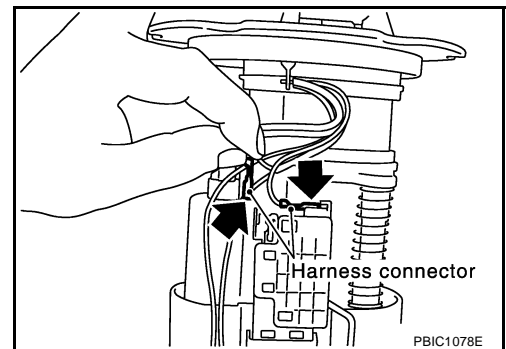

# FUEL LEVEL SENSOR UNIT, FUEL FILTER AND FUEL PUMP ASSEMBLY

- Using suitable tool, pull up tabs points as shown in the figure (two points) to release the lock.

**CAUTION:**

**Be careful not to damage it.**

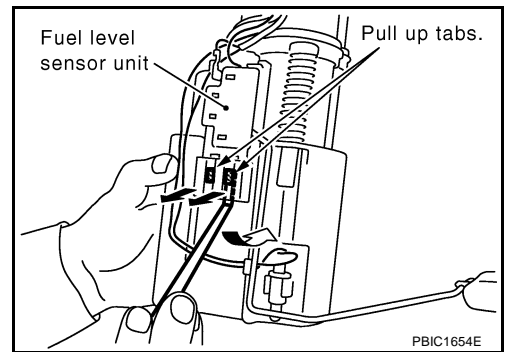

- After fixing tabs are disengaged, slide fuel level sensor unit out in direction shown by the arrow.

**CAUTION:**

**Do not disassemble fuel filter and fuel pump assembly.**

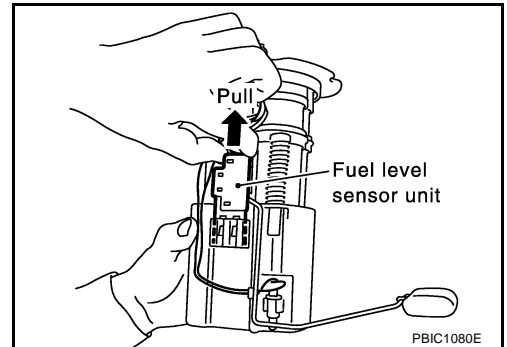

## ASSEMBLY

- Check for damage of fuel level sensor unit installation position on the side of fuel filter and fuel pump assembly.
- Slide fuel level sensor unit until it aligns to installation groove, then insert it until stop.
  - Insert until you hear a “click” sound and actually feel the engagement.
  - After inserting, apply force in reverse direction (removal direction) to ensure it cannot be pulled out.
- Connect harness connector.
  - Securely insert harness connector until it stops.

# FUEL TANK

PFP:17202

## FUEL TANK

### Removal and Installation

ABS009Q0

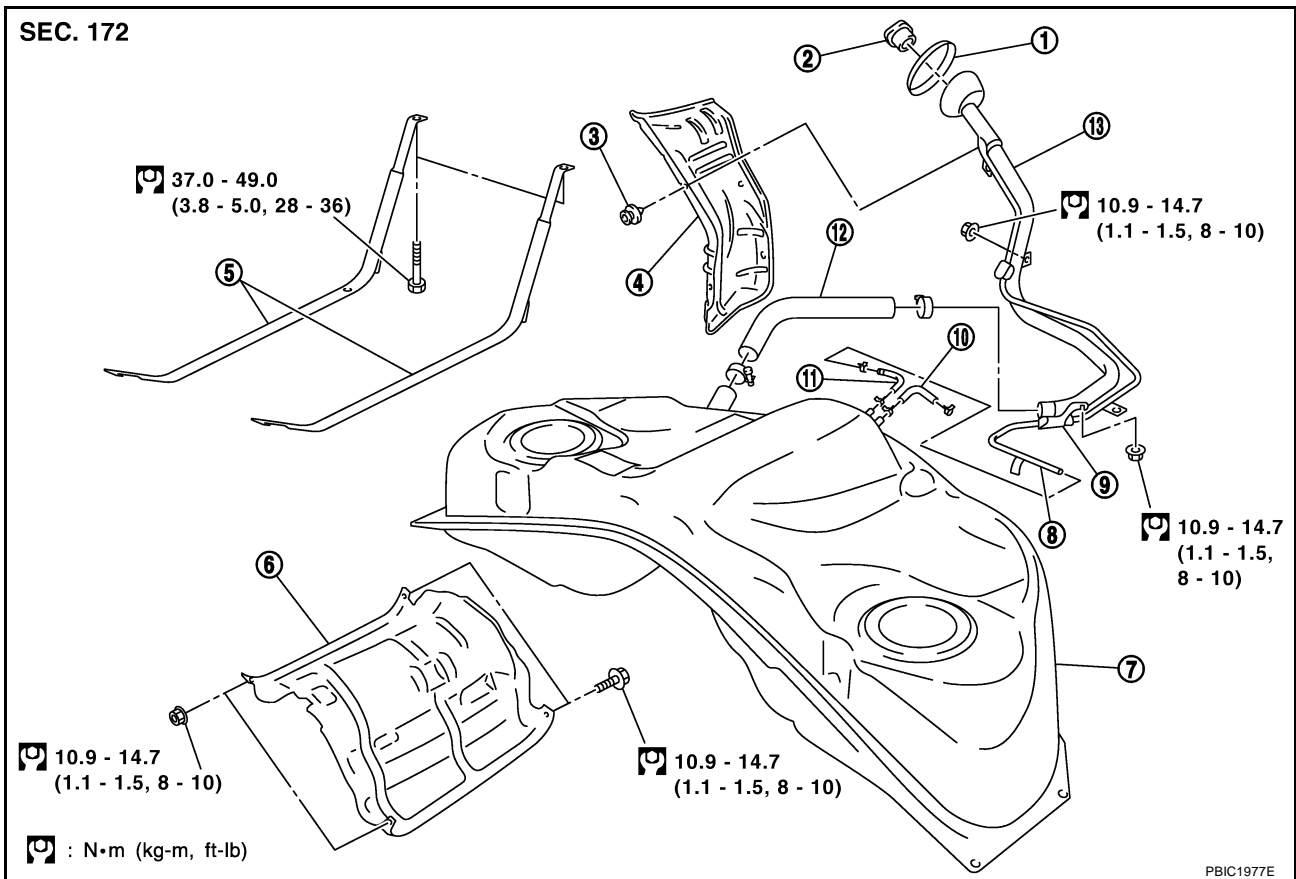

- |                               |                            |                        |
|-------------------------------|----------------------------|------------------------|
| 1. Grommet                    | 2. Fuel filler cap         | 3. Clip                |
| 4. Fuel filler tube protector | 5. Fuel tank mounting band | 6. Fuel tank protector |
| 7. Fuel tank                  | 8. Vent tube               | 9. Vent hose           |
| 10. EVAP hose                 | 11. Vent hose              | 12. Fuel filler hose   |
| 13. Fuel filler tube          |                            |                        |

### REMOVAL

#### WARNING:

Be sure to read "General Precautions" before working on the fuel system. Refer to [FL-3, "General Precautions"](#).

- Drain fuel from fuel tank if necessary. Refer to [FL-4, "REMOVAL"](#).
  - Perform work on level place.
1. Perform steps 2 to 7 of "REMOVAL" in "FUEL LEVEL SENSOR UNIT, FUEL FILTER AND FUEL PUMP ASSEMBLY" on main and sub fuel level sensor units. Refer to [FL-4, "REMOVAL"](#).
  2. Remove tunnel stay. Refer to [RSU-5, "REAR SUSPENSION ASSEMBLY"](#).
  3. Remove exhaust front tube, center muffler and main muffler. Refer to [EX-3, "EXHAUST SYSTEM"](#).
  4. Remove propeller shaft. Refer to [PR-5, "REAR PROPELLER SHAFT"](#).

#### CAUTION:

**Do not impact or damage propeller shaft tube.**

5. Remove parking rear brake cables. Refer to [PB-3, "PARKING BRAKE CONTROL"](#).
6. Remove rear suspension assembly. Refer to [RSU-5, "REAR SUSPENSION ASSEMBLY"](#).
7. Remove fuel tank protector.

# FUEL TANK

8. Disconnect fuel filler hose, vent hose and EVAP hoses at fuel tank side.

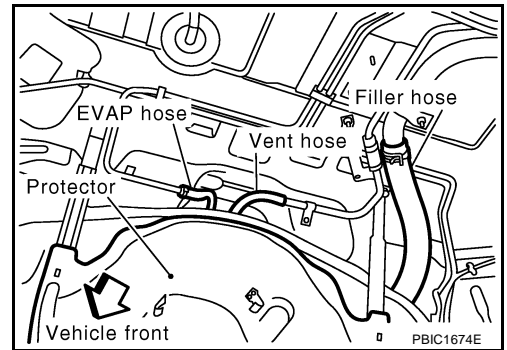

9. Remove fuel tank mounting band bolts while supporting fuel tank.

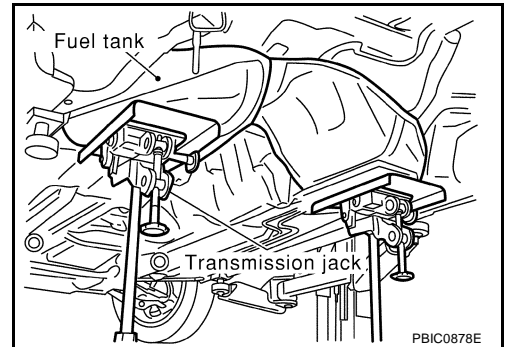

10. Supporting with hands, descend transmission jack carefully, and remove fuel tank.

## CAUTION:

- Make sure that all connection points have been disconnected.
- Confirm there is no interference with vehicle.

11. Remove fuel filler tube, if necessary.

## INSTALLATION

Note the following, and install in the reverse order of removal.

- Surely clamp fuel hoses and insert hose to the length below.

**Fuel filler hose : 35 mm (1.38 in)**

**The other hoses : 25 mm (0.98 in)**

- Be sure hose clamp is not placed on swelled area of fuel tube.
- Tighten fuel hose clamp so that the distance between its lugs becomes to the following.

**Fuel tank side : 8 - 12 mm (0.31 - 0.47 in)**

**Fuel filler tube side : 5.7 - 9.7 mm (0.224 - 0.382 in)**

- To connect quick connector, refer to [FL-7, "Quick Connector"](#).

## INSPECTION AFTER INSTALLATION

Use the following procedure to check for fuel leaks.

1. Turn ignition switch "ON" (with engine stopped), and check connections for leakage by applying fuel pressure to fuel piping.
2. Start engine and rev it up and make sure there are no fuel leaks at the fuel system connections.

# SERVICE DATA AND SPECIFICATIONS (SDS)

## SERVICE DATA AND SPECIFICATIONS (SDS)

PFP:00030

### Standard and Limit

ABS009QR

Fuel tank capacity	Approx. 76 ℓ (20-1/8 US gal, 16-3/4 Imp gal)
--------------------	--

### Tightening Torque

ABS009QS

Unit : N·m (kg·m, ft·lb)  
N·m (kg·m, in·lb)\*

Main fuel level sensor unit, fuel filter and fuel pump assembly	2.0 - 2.5 (0.20 - 0.26, 18 - 22)*
Sub fuel level sensor unit	2.0 - 2.5 (0.20 - 0.26, 18 - 22)*
Fuel tank mounting band	37.0 - 49.0 (3.8 - 5.0, 28 - 36)
Fuel filler tube	10.9 - 14.7 (1.1 - 1.5, 8 - 10)
Fuel tank protector	10.9 - 14.7 (1.1 - 1.5, 8 - 10)